

9800



9800 with
full-motion
video topper

Triton's 9800 Series represents a revolutionary way of thinking in ATMs. With a sleek design and advanced revenue and compliance features, the 9800 is perfectly suited for both high-end retailers and financial institutions.

Unlike many ATMs in the field today that are outdated and in need of expensive upgrades in order to be regulation compliant, the 9800 is an economical, state-of-the-art option that's ready to perform from day one. Standard features like EPP (Encrypting PIN Pad), Triple DES software and full

The affordable alternative to high-end ATMs.

ADA compliance make it a very attractive alternative over more expensive ATMs.

The 9800's 12.1" LCD transaction screen enables customized video clips, ads, and in-store promotions to be viewed continuously during ATM transactions—while an optional full-motion video topper provides additional advertising and branding opportunities.

With multiple communication options and the look and feel of a traditional ATM, Triton's 9800 is the perfect adaptable, full-service ATM that high-end retailers and financial institutions can afford.

9800 IN DETAIL



A revolutionary way of thinking in ATMs

*FEATURES:

- One to four cassettes
- 12.1" (308 mm) color LCD transaction screen with 800 x 600 resolution
- 80 mm thermal printer
- 128 MB RAM (expandable up to 512 MB)
- Microsoft® Windows 2000 operating system
- PC-based Intel Celeron™ processor
- Peripherals:
 - 10 GB hard drive
 - floppy drive
 - 52x CD ROM drive
- 56k internationally certified modem
- Dip style card reader or optional EMV smart card reader
- Americans with Disabilities Act (ADA) compliant
- Audio transactions for the visually impaired
- Rear access option
- UL 291 Business Hours Service cabinet or optional UL 291 Level 1 safe
- Encrypting PIN Pad (EPP) to comply with international encryption standards, Triple DES compliant
- Electronic lock standard, MAS Hamilton lock optional

- Multi-lingual capabilities
- Dial-up, satellite, and TCP/IP communication options
- Triton Connect™ compatible
- Back-lit graphic topper option
- Dimensions
 - 20.5" wide (521 mm)
 - 24.8" deep (630 mm)**
 - 64.5" high (1640 mm)
 - without topper
 - 80.1" high (2035 mm)
 - with topper
- Weight 271 lbs. (123 kg)
 - weight varies with options
- Advertising revenue potential:
 - Decal and signage
 - Couponing
 - Transaction screen
 - Full-motion video option

OPERATING SPECS:

- Temperature 10° - 40° C
50° - 104° F
- Relative Humidity 20%-80%
Non-condensing
- Power Consumption:
- Internal Power Supply
4.0 A @ 115 VAC at 60 Hz
2.0 A @ 230 VAC at 50 Hz
- Computer Power Supply
5.0 A @ 115 VAC at 60 Hz
2.5 A @ 230 VAC at 50 Hz



ATM INSTALLATION SPACE REQUIREMENTS FOR ADA COMPLIANCE

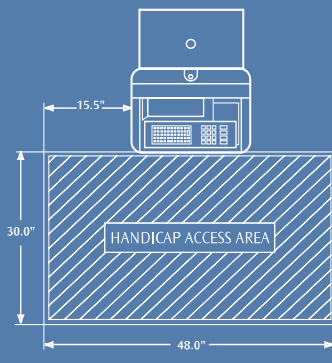

The dimensions shown comply with US Federal ADA guidelines. For installation within the US, be sure to check state and local guidelines for complete compliance. For non-USA installations, check regulations for the country in which the machine will be installed.

*specifications subject to change without notice
**certain models increase depth by 7" (178 mm)

For additional information on any of the ATMs in Triton's line-up, please visit our web site at www.tritonatm.com.

Triton • 522 East Railroad Street • Long Beach, Mississippi 39560 USA
Phone: 1-228-868-1317 • Toll free: USA & Canada 1-800-367-7191
www.tritonatm.com • email: sales@trtn.com



Triton is a registered trademark of Triton Systems of Delaware, Inc. Triton is an operating company of Dover Industries, Inc., a subsidiary of Dover Corporation (NYSE:DOV). © Delaware Capital Formation, Inc., 2002, 2003. All Rights Reserved. DOVER and DOVER logo are registered trademarks of Delaware Capital Formation, Inc., a wholly-owned subsidiary of Dover Corporation.